

# F157

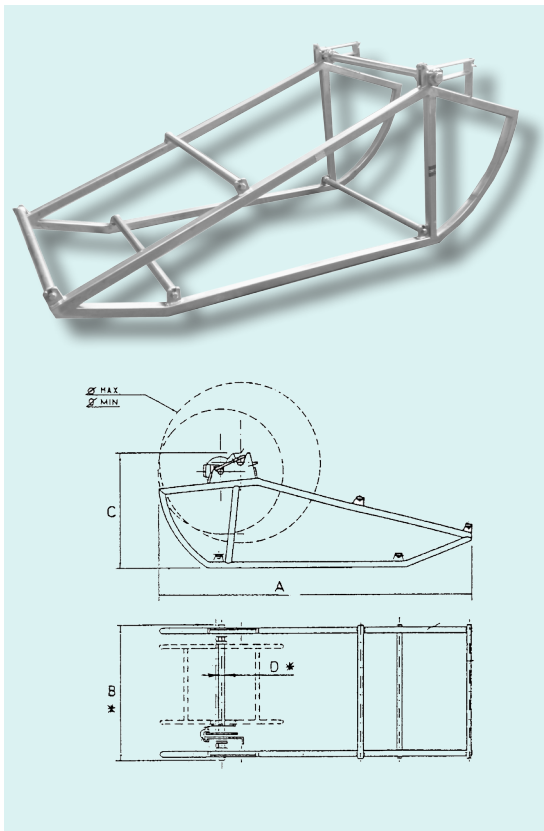

Reel-cradle fit for lifting and unwinding steel rope reel. Fully galvanized. Completely demountable for an easy transport. Complete with reel shaft.

### OPTIONAL DEVICES

- 410.1 Disc brake for braked unwinding (F157.14.5 and F157.19 braking torque 150 daN m)
- 410.4 Disc brake with high brake capacity (F157.19 only - braking torque 280 daN m)

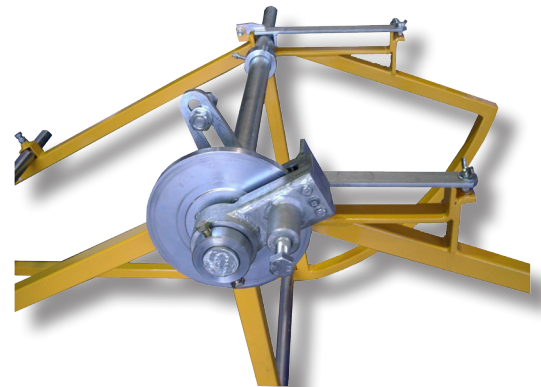

opt.410.1

	Reel diameter min - max	Overall dimensions (A x B x C)	Spindle (ØD)	Load	Weight
	m	m	mm	daN	kg
F157.14.S	1,10 - 1,40	2,50 x 1,10 x 0,95	50	2000	72
F157.19	1,40 - 1,90	3,00 x 1,10 x 1,10	50	2600	160

Dimensions and weights are without optional devices. All data may change without notice. Images and drawings are indicative only.