

F151.235

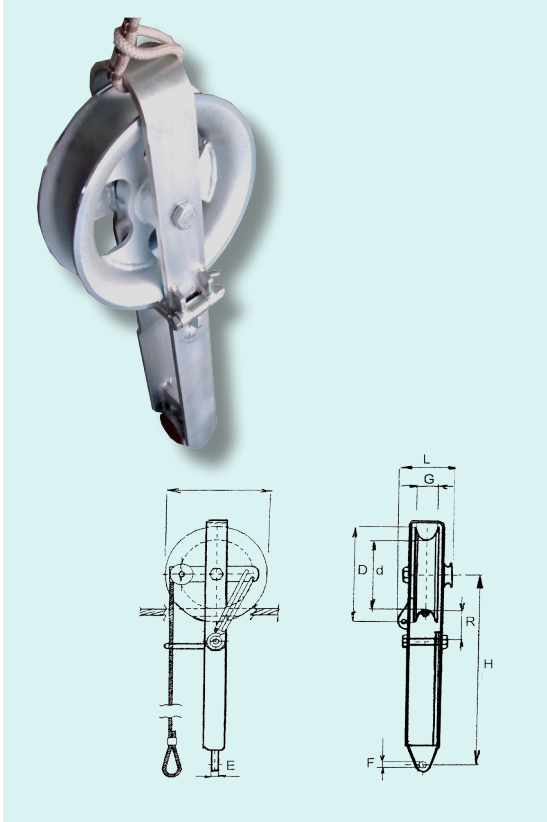

Counter-pull running-out block. Galvanised steel frame, openable side, with swivelling hooks on the ends. Automatic releasing device for recovering the unit.
 vers. AS Galvanised steel pulley mounted on ball bearings.
 vers. BS Aluminium pulley lined with interchangeable nylon ring.

	Dimensions (mm)								Working Load kN	Weight kg
	d	D	E	F	G	H	L	R		
F151.235.AS	240	300	25	25	65	600	170	95	28	21
F151.235.BS	235	300	25	25	50	550	150	95	22	20

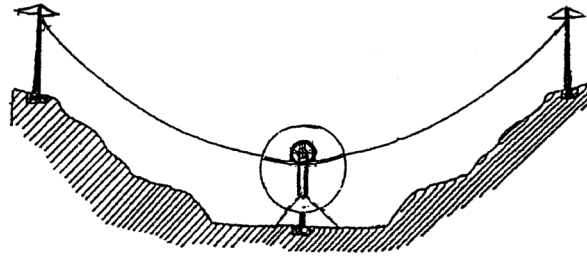

F151



Running out block fit for stringing shield wires. Galvanized steel sheave mounted on ball bearings. Galvanized steel frame with non-fleeting device.

Different attachments available:

- A - swivel hook (optional).
- B - swivel fork (standard).
- C - fix hook (optional).

Blocks with different dimensions can be built on demand.

	Attachment type	Dimensions (mm)								Working Load kN	Weight kg
		d	D	E	F	G	H	L	R		
F151.235.A	A	230	300	25	22	65	400	155	100	28	13
F151.235.B	B/C	230	300	25	20	65	400	155	70	28	13

Dimensions and weights are without optional devices. All data may change without notice. Images and drawings are indicative only.