

F166

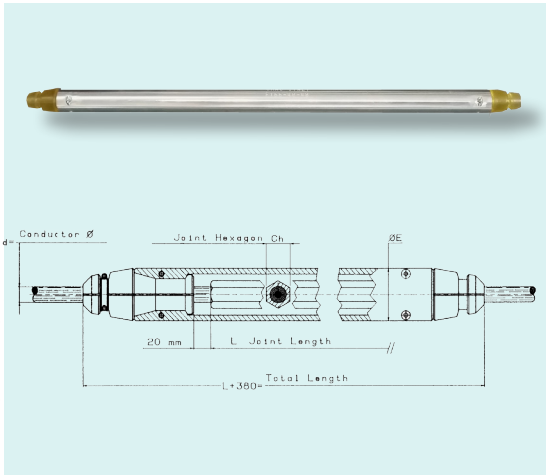

Joint protector made up of two galvanised steel shells. The ends are shaped to host the rubber protections. It is fit to limit the bending radius of the conductor during the passage in the running out blocks.

Note: in the purchase order, please specify the following dimensions:

L = length of the joint after compression

d = conductor diameter

ch = hexagon dimension of the joint after compression

	pulleys with groove	joint protector ext ØE	conductor Ød	L max (1)	Hexagon Ch max	W.L	Weight
	mm	mm	mm	mm	mm	kN	kg
F166.40.1	54/60	50	18	700	28	2,5 - 5	10
F166.60.1	68	57	28	995	40	4 - 6,5	16
F166.65.1*	95	68	32	1080	53	2 - 5	18
F166.92.1*	95	89	50	1240	60	6 - 6,5	32

* special - (1) different lengths on request

F198

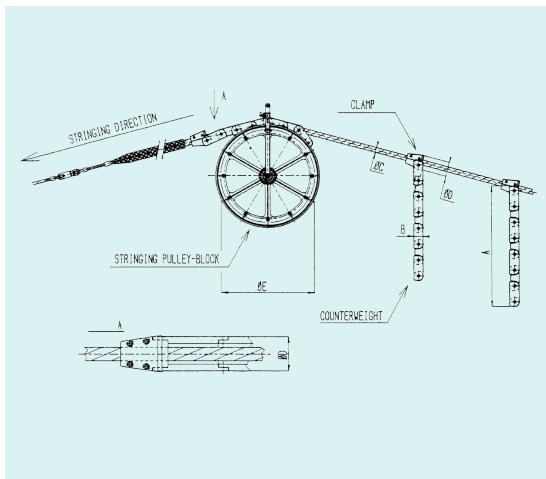

Antitwisting counterweight fit for stringing overhead fiber optic cables (OPGW).

The counterweight allows to avoid the cable twisting during the passage in the running out blocks. Its shape is designed for passing in the grooves of the running out blocks without damaging the cable. A pair of nylon liners prevents damages to the cable. Supplied in metallic case.

Note: counterweights F198 must always be used in pairs.

In the purchase order, please specify the OPGW diameter.

Attention: minimum distance between the two counterweights approximately 3m.

	Dimensions (mm)		Weight (1)	Conductor ØC	Fit for running out block groove width	
	ØD	A(2)	B	mm	mm	mm
F198.50	50	1000	35	22	9 - 17	350/500 / 60/68
F198.60	64	1300	50	38	14 - 23	500/800 / 68
F198.88	80	1800	60	46	23 - 30	650/800 / 95

(1) weight of a pair - (2) indicative length

F198.1

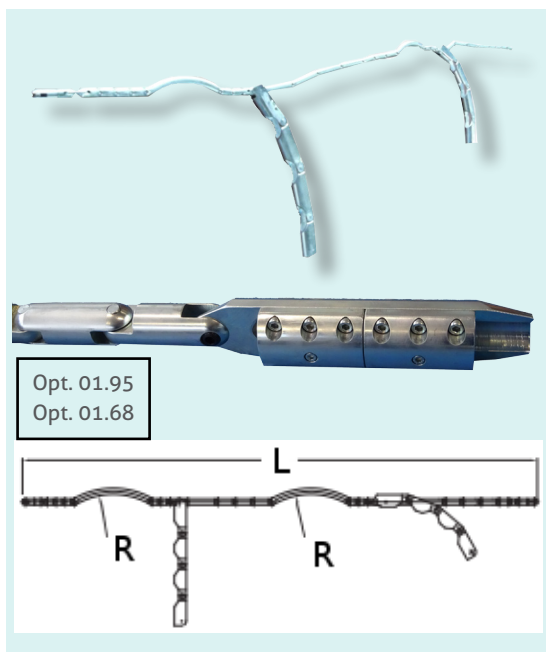

Antitwisting counterweight fit for stringing overhead fiber optic cables (OPGW). The counterweight allows to prevent the cable from twisting during the passage in the running out blocks.

Its shape is designed for passing in the grooves of the running out blocks without damaging the cable. To be matched with a pulling stocking (not supplied - to be quoted on request).

OPTIONAL DEVICES

01.95 Clamp for OPGW conductor to be applied at the head of the counterweight, instead of the pulling stocking. Running out block groove width = 95 mm.

Note: Specify the diameter of the conductor OPGW.

01.68 Clamp for OPGW conductor to be applied at the head of the counterweight, instead of the pulling stocking. Running out block groove width = 68 mm.

Note: Specify the diameter of the conductor OPGW.

	Dimensions (mm)		Weight	W.L.	Ø Running out block
	L	R	kg	kN	mm
F198.1.65	3900	325	60	10	350 / 500 / 650
F198.1.100	4300	500	63	10	800 / 1000

Dimensions and weights are without optional devices. All data may change without notice. Images and drawings are indicative only.