

C155.B



Line-car for 2 linemen, fit for 2-, 3- or 4-bundle conductor lines.
 Made of light alloy structure with nylon wheels mounted on ball-bearings.
 Stationary brake and metercounter.
 Max load: 200 daN

FEATURES

Capacity 200 kg

OPTIONAL DEVICES

02 Aluminium wheels

n. of conductors of the line: height 'B'	2 conductors B = 1200 mm	3 conductors B = 1550 mm	4 conductors B = 1550 mm
line car without engine	C155.B.2 weight 45 kg	C155.B.3 weight 50 kg	C155.B.4 weight 55 kg

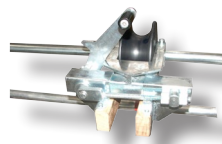

Stationary brake



Metercounter

C155.BM

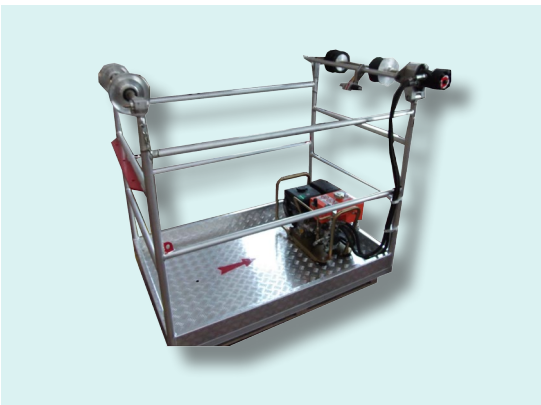

Motorized line-car for 2 linemen, fit for 2-, 3- or 4-bundle conductor lines.
 Made of light alloy structure with nylon wheels mounted on ball-bearings.
 Transmission axle with high grip rubber wheels. Stationary brake and metercounter.

FEATURES

Capacity 200 kg
 Gasoline engine 5 hp, 48 cc with hydraulic power unit
 Translation speed 0-40 m/min
 Max slope 40%.
 Removable engine and hydraulic transmission group.

OPTIONAL DEVICES

02 Aluminium wheels

n. of conductors of the line: height 'B'	2 conductors B = 1200 mm	3 conductors B = 1550 mm	4 conductors B = 1550 mm
line car with engine	C155.BM.2 weight 115 kg	C155.BM.3 weight 125 kg	C155.BM.4 weight 140 kg

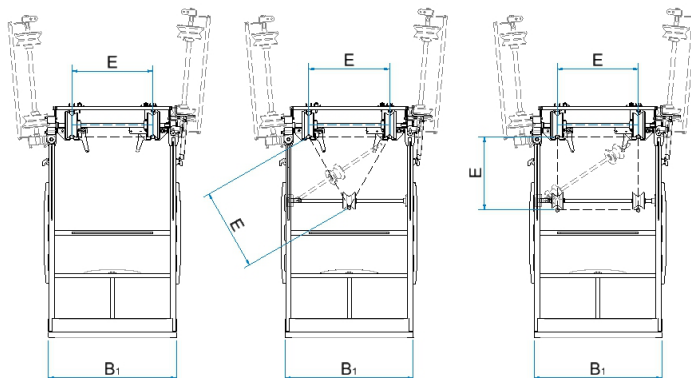
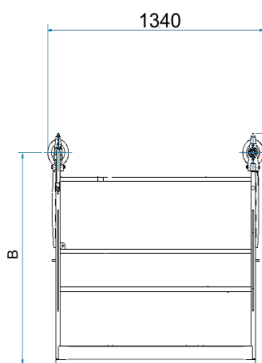

note:the dimensions E are adjustable 400-457-500-600 mm. Line cars with different dimensions can be produced on request.

Dimensions and weights are without optional devices. All data may change without notice. Images and drawings are indicative only.