

F127

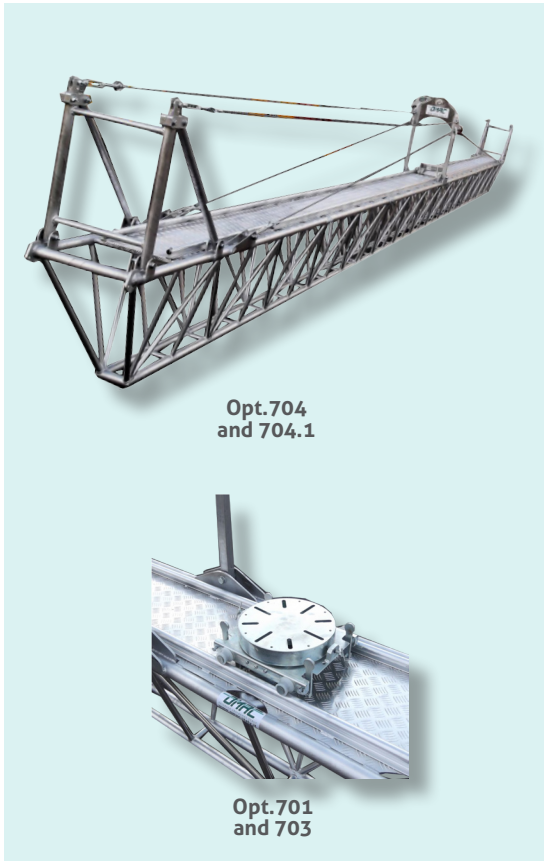

Suspension platform for overhead line works. Aluminium alloy structure. Made of two or more trapezoidal sections, with central fitting and lateral hooks for anchoring. Complete with wire ropes and turnbuckles.

OPTIONAL DEVICES

- 701 Trolley for press, swivelling 360°.
- 703 Rail for press-trolley.
- 704 Double-side antifall protection.
- 704.1 Single-side antifall protection.

On demand, we build suspension platforms with higher capacities or different lengths

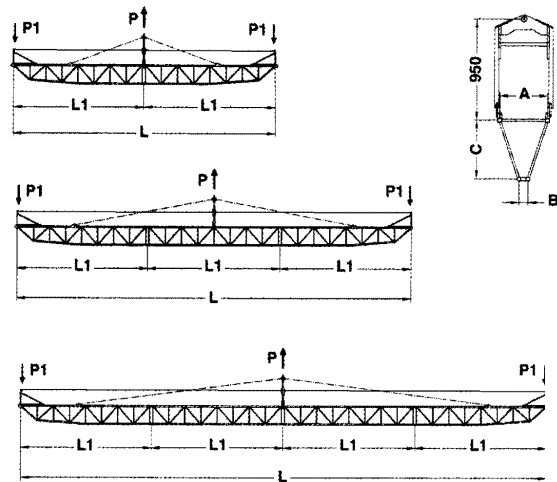

	Total length L	Length of each section L1	Working load P1	Total working load P1+P1 (P)	Breaking load	Dimensions (mm)			Weight (¹)
	m	m	daN	daN	daN	A	B	C	kg
F127.4	4	4	300	600	1800	350	90	400	50
F127.5	5	5	300	600	1800	350	90	400	59
F127.6 (²)	6	6	300	600	1800	350	90	400	64
F127.6.2	6	3+3	300	600	1800	350	90	400	69
F127.8.2	8	4+4	300	600	1800	350	90	450	85
F127.12.2 (²)	12	6+6	300	600	1800	350	90	450	115
F127.14.3	14	5+4+5	300	600	1800	350	90	450	130
F127.16.3 (²)	16	5+6+5	300	600	1800	350	90	450	140
F127.18.3	18	6+6+6	300	600	1800	350	90	450	164
F127.20.4 (²)	20	5+5+5+5	300	600	1800	450	90	550	198

(¹) weight including 1 single antifall device opt.704.1; (²) standard length

Dimensions and weights are without optional devices. All data may change without notice. Images and drawings are indicative only.